

PK 15500

Performance

PALFINGER



UNIT LOADS ARE ITS SPECIALITY



FOR THE PK 15500 *PERFORMANCE* → FUNCTIONALITY IS IN THE FOREFRONT

The new PK 15500 *Performance* is the ideal crane for handling unit loads. It can lift light machinery and heavy structural components with ease. Thanks to years of practical experience and PALFINGER technical know-how it brings high efficiency to any job!



Return oil use

Use of the return oil in the extension system increases the operating speed by 30 per cent.



Load-holding valves

They prevent the crane arms from dropping and are fitted as standard on the elevating, arm and extension cylinder. The valves are positioned in such a way that they are protected from being damaged.



Ergonomic crane control

The operating levers for all crane functions are ergonomically arranged on the console. This provides comfortable, efficient working. The control console is mounted so that it is easy to service.



Central lubrication

For all bearings on the base frame.



Outrigger width

The PK 15500 *Performance* fits onto all normal truck chassis designs. Three outrigger widths are possible: 4.6 m (15' 1") mechanical, 5.6 m (18' 4") and 6.6 m (21' 8") hydraulic.



Control valve

It functions proportionally, is ergonomically arranged and the low leverage permits very sensitive crane control.



DER PK 15500 PERFORMANCE IS WELL SUPPORTED BY MORE THAN 1400 PALFINGER CONTRACT PARTNERS WORLDWIDE



Adjustable slide blocks

Internally routed oil ducts

On the multiple extensions there are no hydraulic hoses between the cylinders. The internally routed oil passages make it possible to have a compact boom design.



Extension system

The extension cylinders are guided in Jordal rails over rollers.

Height compensation



Hose equipment for accessories

With this option you can provide the oil supply to accessories. The hoses are routed in compact troughs and plastic link chains. They are thus optimally protected.

Optional

- The PALFINGER radio control system with digital data transmission
- The PALTRONIC 50 electronic control system
- The hydraulic overload safety device
- Hose equipment for accessories

THE PK 15500 PERFORMANCE ALREADY MEETS THE REQUIREMENTS OF THE FUTURE EN 12999 CRANE STANDARD

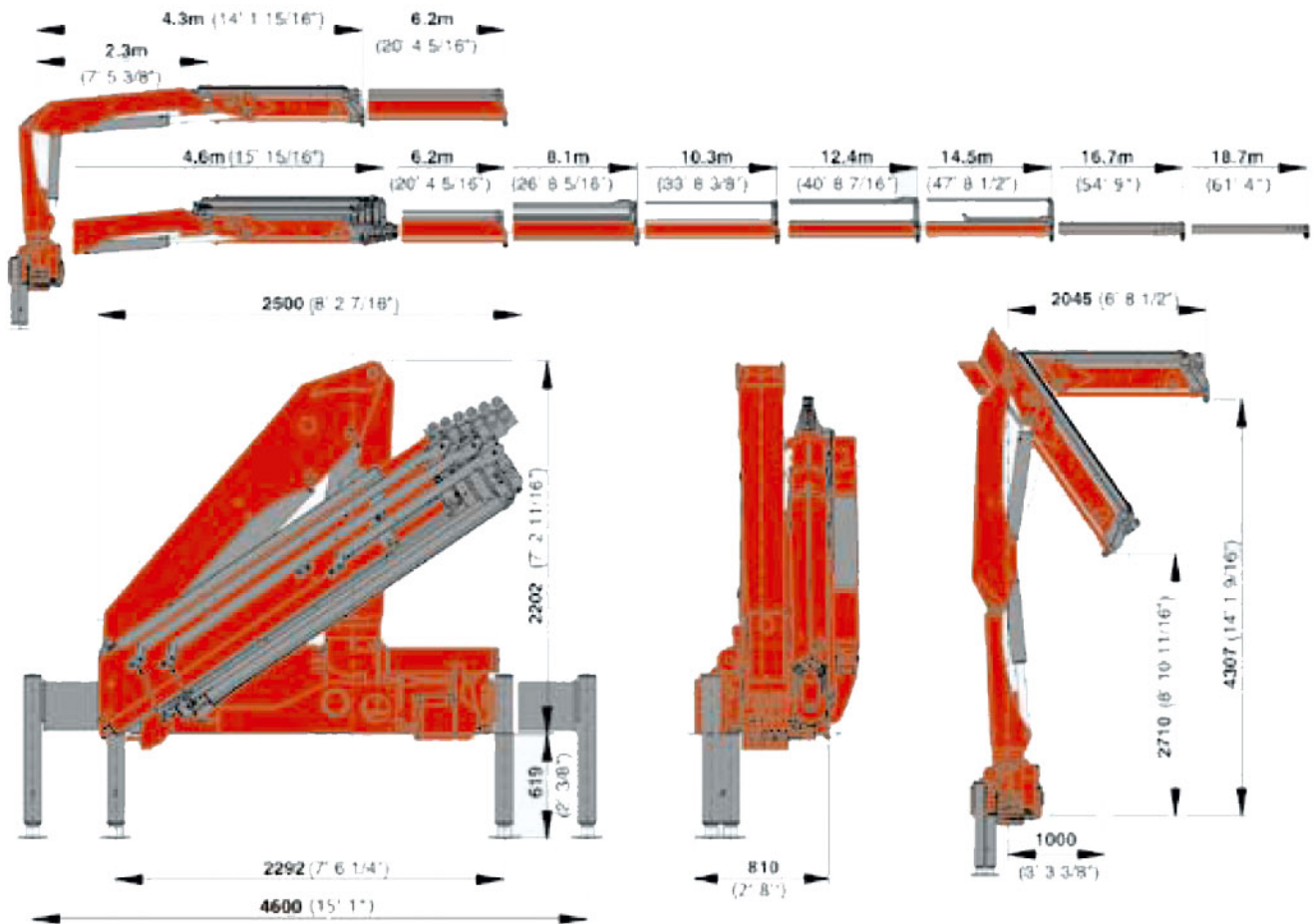

PK 15500 Performance		
Technical specifications (DIN 15018 H1-B3)		
Max. lifting moment	14.6 mt/143.2 kNm	105580 ft.lbs
Max. lifting capacity	6200 kg/60.8 kN	13670 lbs
Max. hydraulic outreach	14.5 m	47' 7"
Maximum outreach	18.7 m	61' 4"
Slewing angle	420°	

PK 15500 Performance		
Standard crane		
Slewing torque	1.8 mt/17.7 kNm	13050 ft.lbs
Stabilizer spread standard	4.6 m	15' 1"
Stabilizer spread maximum	6.6 m	21' 8"
Fitting space required	0.81 m	2' 8"
Width folded	2.5 m	8' 2"
Operating pressure	300 bar	4350 psi
Recommended pump capacity	from 40 l/min.	8.8 imp.gal./min. 10.6 US gal./min
by radio remote control and LS-System	to 60 l/min.	13.2 imp.gal./min. 15.9 US gal./min
Dead weight (without mounting parts, pump and oil)	1619 kg 3570 lbs	

Executions shown in the leaflet are not always corresponding to standard execution. Country-specific regulations are to be observed upon attachment.



THIS CRANE OFFERS THE HIGHEST LEVEL OF QUALITY, SAFETY AND RELIABILITY

Max. lifting capacities

PK 15500 Performance			
hydraulic			
Outreach		Capacity	
2.3 m	6200 kg	7' 7"	13670 lbs
4.5 m	3260 kg	14' 9"	7190 lbs
6.1 m	2380 kg	20' 0"	5250 lbs

PK 15500 Performance A			
hydraulic			
Outreach		Capacity	
2.3 m	6100 kg	7' 7"	13450 lbs
4.5 m	3140 kg	14' 9"	6920 lbs
6.1 m	2250 kg	20' 0"	4960 lbs
8.0 m	1690 kg	26' 3"	3730 lbs

PK 15500 Performance B			
hydraulic			
Outreach		Capacity	
2.0 m	6000 kg	6' 7"	13230 lbs
4.5 m	3040 kg	14' 9"	6700 lbs
6.1 m	2140 kg	20' 0"	4720 lbs
8.0 m	1570 kg	26' 3"	3460 lbs
10.1 m	1230 kg	33' 2"	2710 lbs
manual			
12.3 m	930 kg	40' 4"	2050 lbs
14.4 m	740 kg	47' 3"	1630 lbs
16.6 m	600 kg	54' 6"	1320 lbs

PK 15500 Performance C			
hydraulic			
Outreach		Capacity	
2.0 m	5850 kg	6' 7"	12900 lbs
4.5 m	2960 kg	14' 9"	6530 lbs
6.1 m	2050 kg	20' 0"	4520 lbs
8.0 m	1470 kg	26' 3"	3240 lbs
10.1 m	1110 kg	33' 2"	2450 lbs
12.2 m	910 kg	40' 0"	2010 lbs
manual			
14.3 m	710 kg	46' 11"	1570 lbs
16.5 m	580 kg	54' 2"	1280 lbs
18.4 m	480 kg	60' 4"	1060 lbs

PK 15500 Performance D			
hydraulic			
Outreach		Capacity	
2.0 m	5750 kg	6' 7"	12680 lbs
4.5 m	2860 kg	14' 9"	6310 lbs
6.1 m	1940 kg	20' 0"	4280 lbs
8.0 m	1350 kg	26' 3"	2980 lbs
10.1 m	990 kg	33' 2"	2180 lbs
12.2 m	780 kg	40' 0"	1720 lbs
14.3 m	650 kg	46' 11"	1430 lbs
manual			
16.5 m	520 kg	54' 2"	1150 lbs
18.4 m	430 kg	60' 4"	950 lbs

PK 15500 Performance

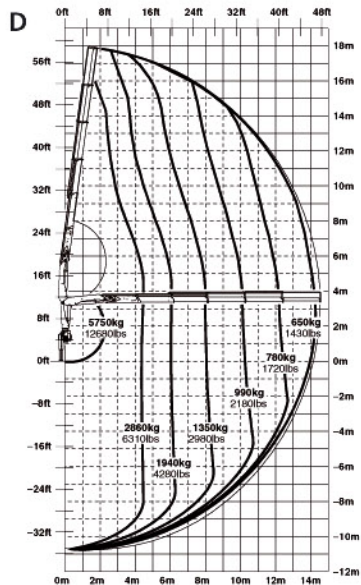
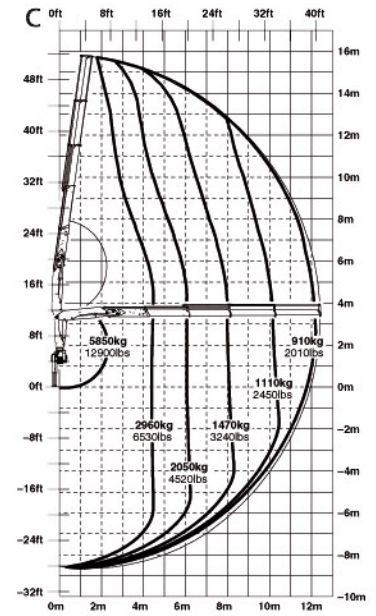
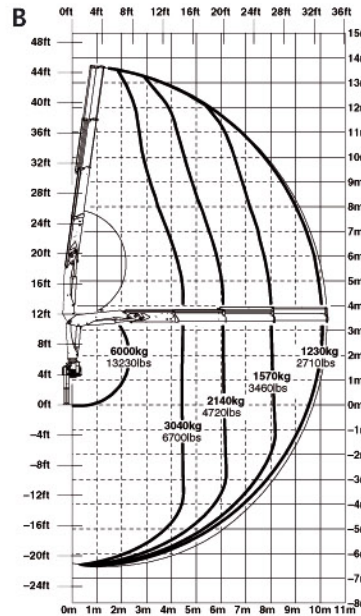
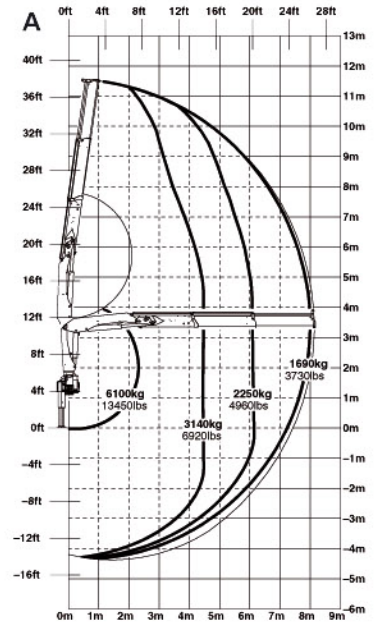
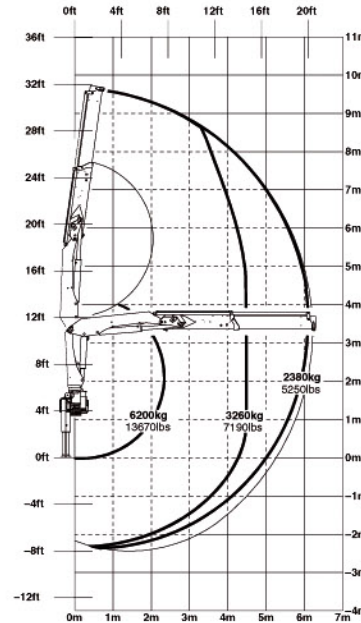

The reaches are indicated for a 20° main boom position and are therefore not the maximum ones.